

客户名称:

输出端

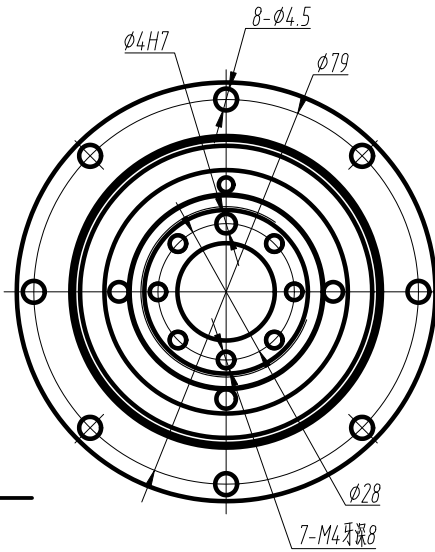

输入端

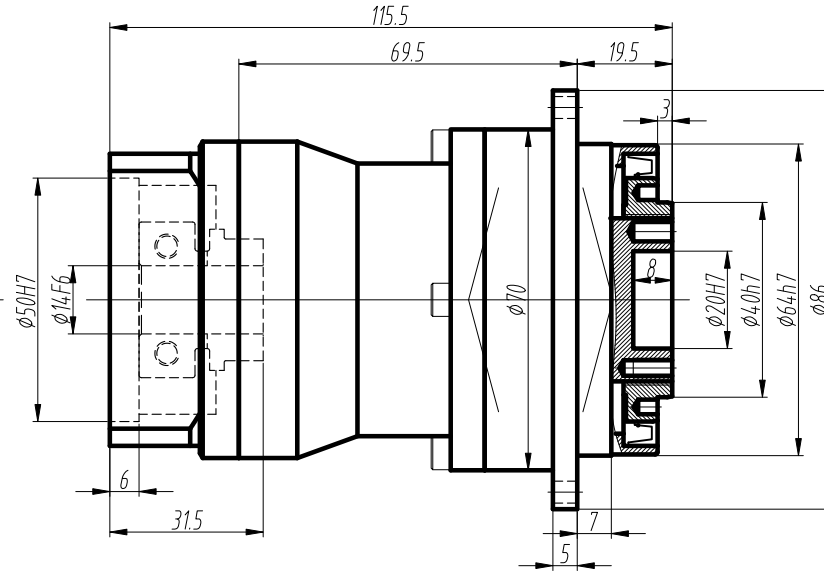
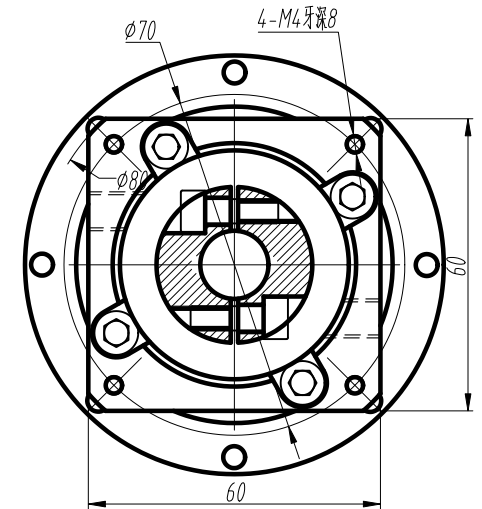

技术参数 technical parameter

额定输出转矩 Nominal torque	—Nm	最大输出转矩 Max.output torque	—Nm
额定输入转速 Rated input speed	3000rpm	最大输入转速 Max.input speed	8000rpm
最大径向力 Max.radial force	4550N	输出转速50rpm, 输出法兰端面受力 Speed 50rpm, Output flange end face	
最大轴向力 Max.axial force	6000N	输出转速100rpm, 输出法兰端面受力 Speed 100rpm, Output flange end face	
满载效率 Maximum efficiency	94%	使用温度 Operating temp	-25°~ +90°
安装方式 Installation method	任意 arbitrarily	润滑方式 Lubrication mode	长效润滑 Permanent lubrication
重量 Weight	1.7Kg	寿命 Average life span	20000h
防护等级 Protection level	IP65	法兰精度 Flange accuracy	DIN 42955-R
标准侧隙 Standard backlash		精密侧隙 Precise backlash	
输出键标准 Key standard			
齿轮精度等级 Gear precision grade	6 GB/T10095-2008		
电机功率 Motor power	400W		
电机安装尺寸 Motor dimensions	φ14*30/φ50*3/4-φ4.5-φ70		

标准轴
Standard output shaft

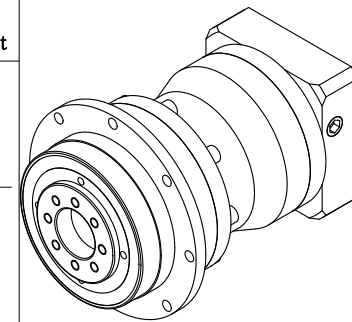
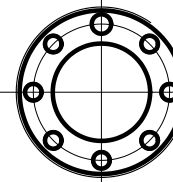

	70	22.5
	50	31.5
	40	29.5
	35	31.5
	28	29.5
	25	31.5
	20	29.5
	16	29.5
减速比(可选择)	额定转矩(Nm)	

OPH雙級尺寸圖

OPH060-L2-()-S2-P2

标记	外数	分区	更改文件号	签名	年月日	图号:	AOPT	
设计			标准化			数量	重量	比例
审核								1:1
工艺			批准					⊕ ⊞